

PRODUCT DATA SHEET

Product Code: 12ozSW
Description: 0.36L(SW) Product Template

CUP SPECIFICATION

Material

Side wall Paper:
SP/DP Side Wall: Single PE
GSM Side Wall: 320g+18
Caliper Side Wall:

Base Reel:
BPCS Code Base Reel:
SP/DP Base Reel: Double PE
GSM Base Reel: 18+210+18
Callper Base Reel:

Outer Sleeve:
BPCS Code Outer Slee:
SP/DP Outer Sleeves:
GSM outer Sleeve:
Caliper Outer Sleeve:

Cup Dimension(mm)

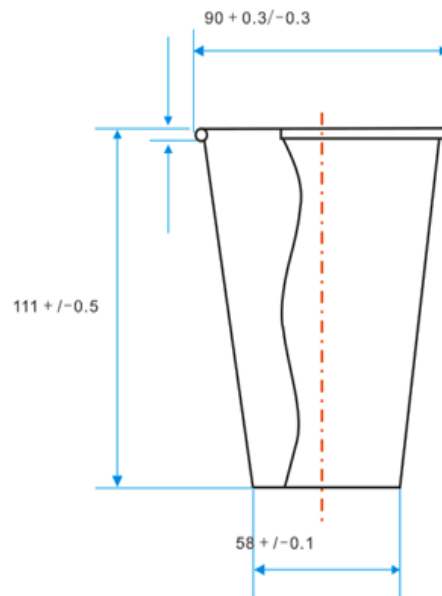

Unit Weight(g): 11.25

PACKAGING SPECIFICATION

Case Specification

Ext.Height(mm): $470 \pm 10\%$
Ext.Width(mm): $370 \pm 10\%$
Ext.Length(mm): $460 \pm 10\%$
Ext.Volume(cu.m): $0.081 \pm 10\%$
Case weight(kg) $1.7 \pm 10\%$
Full Case weight(kg) $12.8 \pm 10\%$
Cups per sleeve: 50
Sleeve per Case: 20
Cups per case: 1000

Pallet Specification

Height(mm)incl.pallet:
Width(mm):
Length(mm):
Pallet Weight(Kg)
Cups per pallet:
Cases per pallet:
Cases per layer:
Layers:
Pallet type(Std/Euro):

**All cups are protected by PE-Sleeves and 5-layer carton*