

PRODUCT DATA SHEET

Product Code: 8ozSW
Description: 0.25L(SW) Product Template

CUP SPECIFICATION

Material

Side wall Paper:
SP/DP Side Wall: Single PE
GSM Side Wall: 280g+18
Caliper Side Wall:

Base Reel:
BPCS Code Base Reel:
SP/DP Base Reel: Double PE
GSM Base Reel: 18+210+18
Callper Base Reel:

Outer Sleeve:
BPCS Code Outer Sleeve:
SP/DP Outer Sleeves:
GSM outer Sleeve:
Caliper Outer Sleeve:

Cup Dimension(mm)

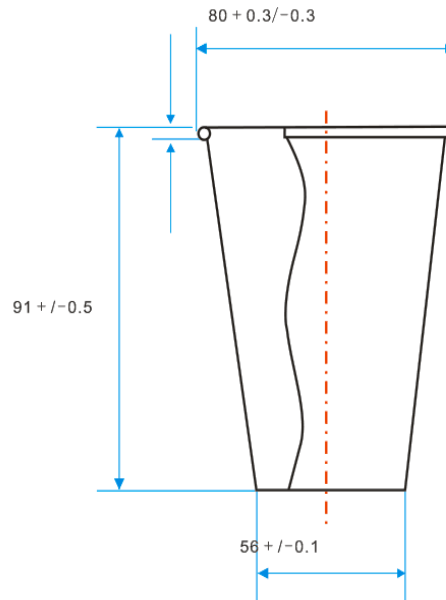

Unit Weight(g): 7.5

PACKAGING SPECIFICATION

Case Specification

Ext.Height(mm): 390±10%
Ext.Width(mm): 325±10%
Ext.Length(mm): 365±10%
Ext.Volume(cu.m): 0.051±10%
Case weight(kg) 1.5±10%
Full Case weight(kg) 9±10%
Cups per sleeve: 50
Sleeve per Case: 20
Cups per case: 1000

Pallet Specification

Height(mm)incl.pallet:
Width(mm):
Length(mm):
Pallet Weight(Kg)
Cups per pallet:
Cases per pallet:
Cases per layer:
Layers:
Pallet type(Std/Euro):

**All cups are protected by PE-Sleeves and 5-layer carton*